



**BALLASTS ENCASTRABLES
POUR LAMPES A VAPEUR
DE SODIUM HAUTE PRESSION**
50 - 1000W
Avec Igniteur Superposition
220V / 50 Hz

 Jusqu'a 100W: Raccordement type 1 \square 1 - 2,5 mm²

 De 150 a 1000W: Raccordement type 3 \square 1,5 - 4 mm²
VDE 0712 EN61347-60923 tw 130

MODELE	TYPE	BALLAST						COMPENSATION	 	CARACTERIS. PHISQUES				Poids (grs.)	Pieces Emblees
		LAMPE		V / Hz	Inductive I	Temp. Dt	Schemas	Paralele mF ±10% 250V		DIMENSIONS					
		Puissance (W)	Intensite (A)							A (mm)	B (mm)	C (mm)	D (mm)		
HSI-SAPI 5/22	SM 50 12201	50	0,76	220/50	0,37	60	15-20	9	*	106,3	92,3	65	52,3	1075	8
HSI-SAPI 7/22	SM 70 13201	70	1	220/50	0,38	60	15-20	12	*	106,3	92,3	65	52,3	1375	8
HSI-SAPI 10/22	SM 100 14200	100	1,20	220/50	0,44	70	20	13	*	106,3	92,3	65	52,3	1375	8
HSI-SAPI 15/22	SM 150 21201	150	1,80	220/50	0,40	60	20	20	*	117	103	86,6	73	2500	4
HSI-SAPI 25/22	SM 250 22206	250	3	220/50	0,40	70	20	32	*	127	113	86,6	73	3000	4
HSI-SAPI 25/22/2	SM 250 22201	250	3	220/50	0,40	65	20	32	*	137	123	86,6	73	3375	4
HSI-SAPI 40/22	SM 400 23201	400	4,45	220/50	0,44	70	20	50	*	167	153	86,6	73	4700	4
SAPI-HSI 60/22		600	6,10	220/50	0,46	70	20	65	-	148	137,5	102	92	7050	2
HSI-SAPI 100/22		1000	10,3	220/50	0,45	75	20	100	-	203	192,5	102	92	10800	2

SECTION REDUIT (SR)

 Raccordement type 1 \square 1 - 2,5 mm²

HSI-SAPI 15/22/SR	SM 150 15201	150	1,80	220/50	0,41	70	20	20	*	135,3	121,3	65	52,3	2050	8
-------------------	--------------	-----	------	--------	------	----	----	----	---	-------	-------	----	------	------	---

D'autres tensions et frequences sur demande

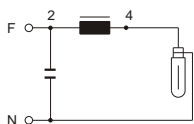
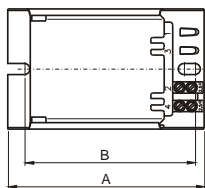
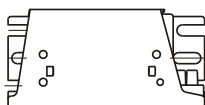
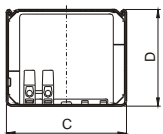
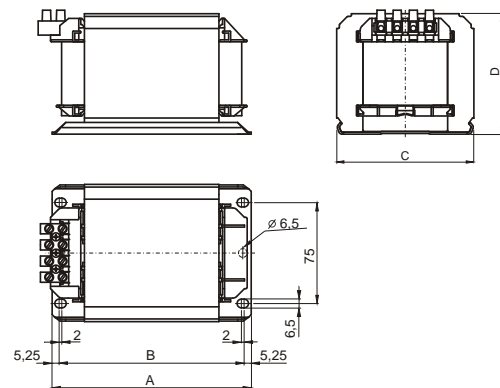
Available avec protection thermique. Augmenter " - P " au modele
600-1000W

15

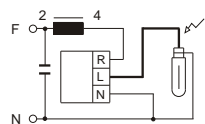

20



Verifier la distance du arranceur a la lampe (Pag. 63)